

**THE JUNIPER
GE90-115B SHORT ENGINE
WASH PROBES**

JMP/GE90-115B/D/4949

(Supplied as set of two)

Fitment Guide



AIRCRAFT SERVICE EQUIPMENT



PROBE ASSEMBLY: Main points and connection to twin hose assembly.

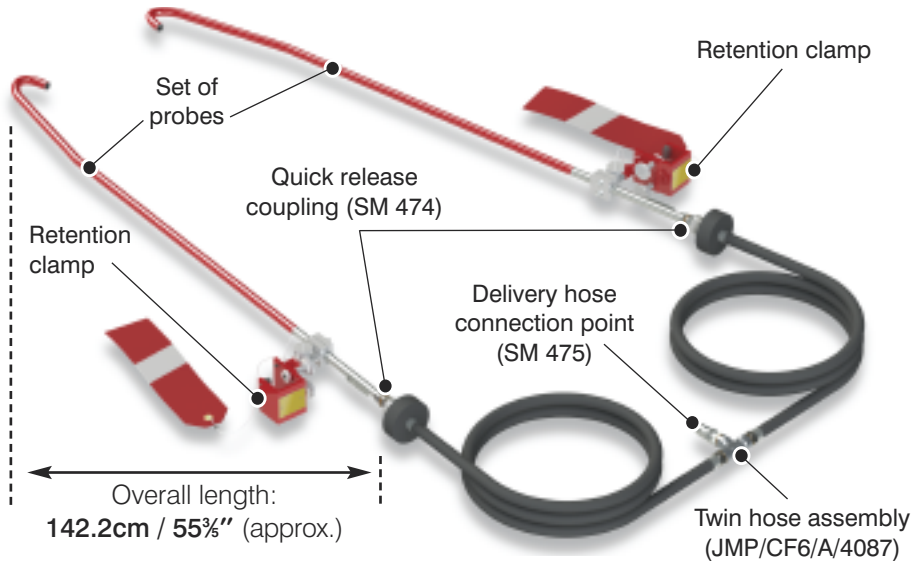

PROBE CARE: Looking after your wash probes

CAUTION: The probes should be handled carefully and stored in the following manner to avoid damage.

When returning probes to the correct compartment in the storage box they should be placed 'top to tail' into the supplied equipment bag after draining them thoroughly.

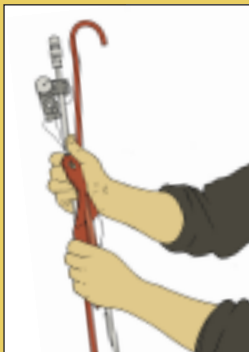

NOTE: Storage boxes are supplied in one of two standard sizes dependent on the size of probes ordered:

Small: (h) 39" x (w) 24" x (d) 15 1/2"

Large: (h) 48 1/2" x (w) 24" x (d) 15 1/2"

Probe fitment to engine.

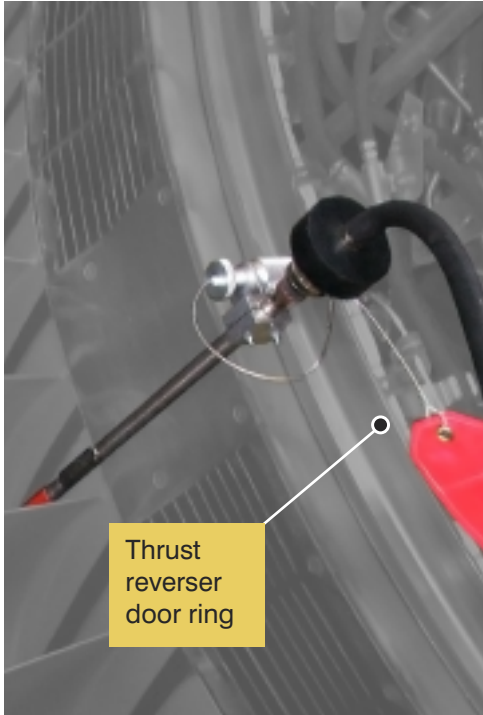

CAUTION:

Ensure that the engine fan is held securely during the fitting of the engine 'j' hook probes.

Separate the probe from the clamping screw by unscrewing the locking knob and then set the tube aside.

Offer up the clamping bracket to the thrust reverser door ring shown above at approximately the **4.00** and **8.00 o'clock** positions and loosely tighten the clamping screw onto the lip of the ring until the nylon pad contacts the face and the bracket sits straight.

Retrieve the probe tube and guide it through the closest outlet guide vanes in relation to the clamping bracket and hook the nozzle over the fan / booster splitter.

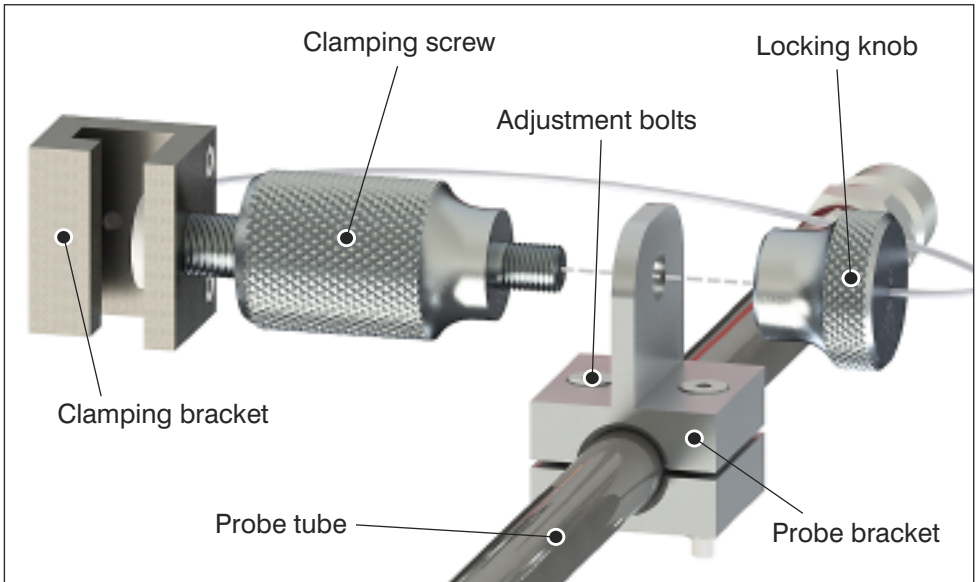



Guide the probes through the fan outlet guide vanes (ogv's) from the aft end at approximately the **4.00** and **8.00 o'clock** positions, aft looking forward.

Hook the probes over the booster/fan splitter so that the nozzle points between the booster inlet guide vanes into the booster.

Locate the probe tube bracket over the stud on the clamping screw and replace and tighten the locking knob. It may be necessary to adjust the bracket along the tube to achieve a suitable fit. (use Allen key provided).

Finally re-tighten the clamping screw so that the probe is held securely.



Connect the twin hose assembly (provided with all compressor wash rigs) to both of the engine probes, making sure that the probes are attached securely to the engine with the hoses attached.

Connect delivery hose from the wash rig to the twin hose assembly.

Note: The probes shown here are for illustrative purposes only and are not necessarily the actual probes featured.

Probe installation is now complete. Please refer to the relevant AMM for flow rate information.

Contact details



Contractors to
H.M. Government Departments
Registered with ISO 9001:2015

A.T.Juniper (Liverpool) Limited Aircraft Service Equipment

Head Office:

Marshall Works, 5-17 Bleasdale Road, Allerton,
Liverpool L18 5JB, United Kingdom

Tel: **+44 (0)151 733 1553**

Fax: **+44 (0)151 734 3166**

Email: **gse@juniper-liverpool.com**

Web: **www.juniper-liverpool.com**

Also At:

Ash House, Prenton Way, North Cheshire Trading Estate,
Wirral CH43 3DU, United Kingdom

PROBE SPARES: Each kit contains replacement parts for a set of two probes.

Replacement **tubes** and **brackets** kits are available for these wash probes. The **tubes (red)** kit consists of the welded tube assembly with red vinylastic coating, ID plate and Tema quick-release coupling. The **bracket (blue)** kit consists of clamping brackets and knobs, warning pennants and talurit cables. The part numbers for each kit is below.

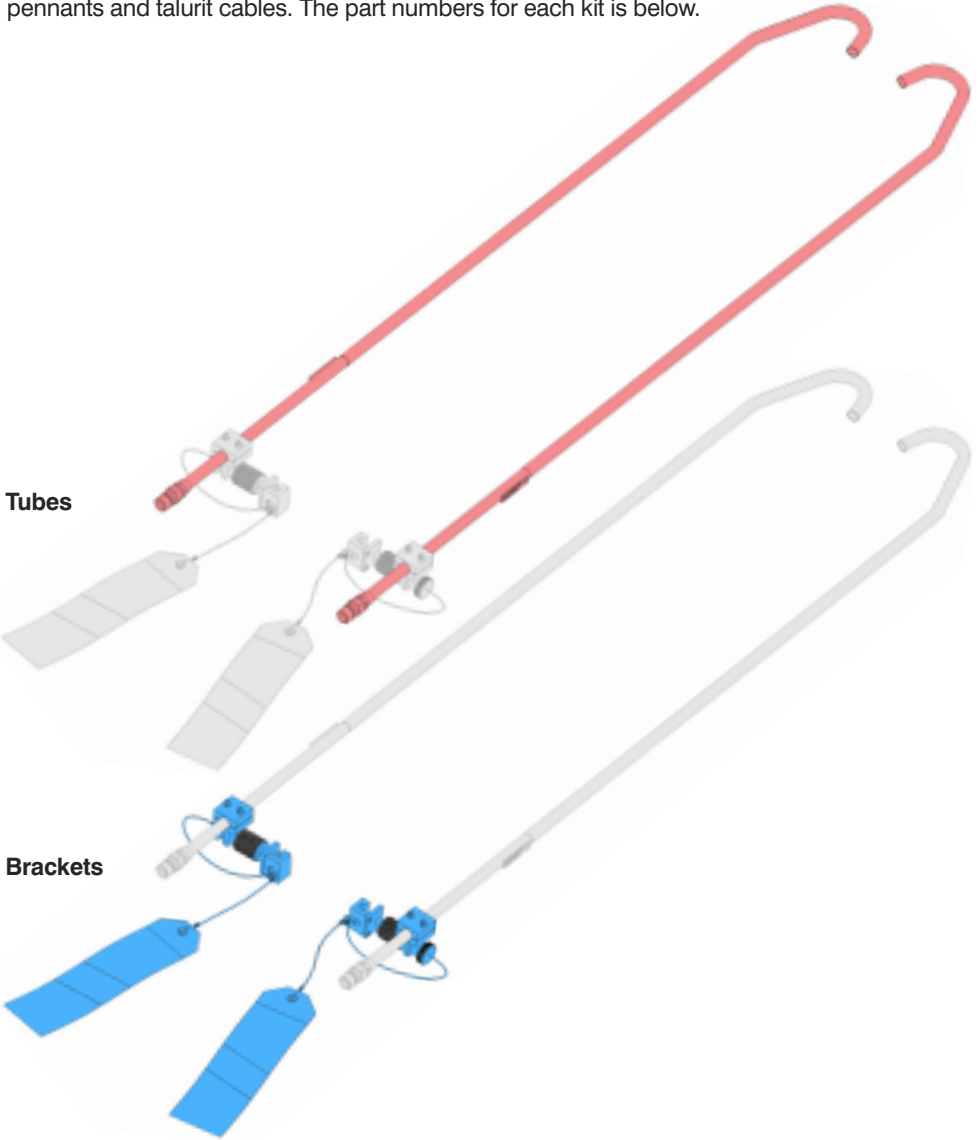

Probe tubes kit JMP/GE90-115B/D/4949/TUBES

Probe brackets kit JMP/GE90-115B/D/4949/BRACKETS