

**THE JUNIPER
CF34-8E ENGINE
WASH PROBES**
JMP/CF34-8E/D/6940

(Supplied as set of two)

Fitment Guide



The CF34-8E long engine wash probes **JMP/CF34-8E/D/6940**



Juniper's high capacity compressor washing rigs



The 2x25 gallon rig
(JMP/CFM56/D/4777/C200)
NSN 1730-99-668-7936

The 2x50 gallon rig
(JMP/LUFT/D/4972/C500)

Delivery hose selection

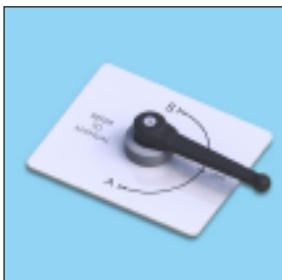

When using CF34-8E engine wash probes, turn the three way selector to position 'B' this ensures selection of the 1/2" bore delivery hose.

Please refer to the relevant AMM for correct flow rate information.

STEP 1: Locating the probe

Caution: Ensure that the engine fan is held securely during the fitting of the engine 'j' hook probes.

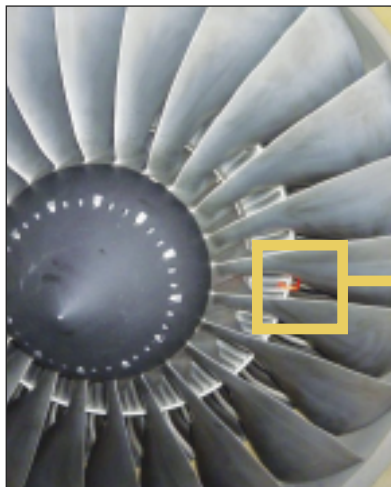

Guide the probes through the fan outlet guide vanes (ogv's) from the aft end, at approximately the **3.00 o'clock** and **9.00 o'clock** positions, aft looking forward.



Put the probes over the booster / fan splitter so that the tips point between the booster inlet guide vanes into the booster.

STEP 2: Securing the spring loaded clamps

Each probe has a single spring loaded clamp which is tensioned against the edge of the engine translating sleeve.

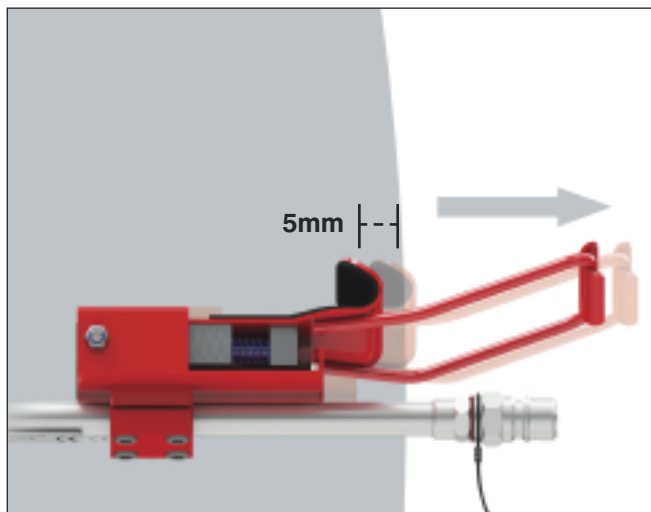

The clamp tightened approximately 5mm inside the edge of the translating sleeve.

For first time fitment to the engine, loosen the tube clamp via the four allen key bolts and dummy fit the probe to the engine.

Once the hook is positioned, visually line up the back edge of the clamp with the edge of the translating sleeve (without hooking it over) and carefully slide the clamp forward a further 5mm (approx.) along the probe tube. Re-tighten the allen key bolts.

Then, using the handle, pull the clamp towards you and hook it gently over the translating sleeve edge until it rests securely against the rubber lining. You should feel the clamp springs tensioning as you hook it over.

Note: *If you are unable to pull the clamp far enough to hook over the sleeve, then the clamp has been positioned too far forward, and if you feel no tensioning of the clamp springs as you hook it over, then the clamp has not been moved forward far enough. In both cases, loosen off the allen key bolts and re-position the clamp before re-tightening and trying again.*

Once the clamps have been positioned correctly they should not require re-adjusting. To remove the clamp simply pull the handle towards you and unhook it from the translating sleeve.

Connect the twin hose assembly (provided with all compressor wash rigs) to both of the engine probes, making sure that the probes are attached securely to

the engine with the hoses attached, then connect delivery hose from the wash rig to the twin hose assembly.

Probe installation is now complete.



Note: *Images used in this guide are for illustrative purposes only and may not accurately represent the engine in question.*

Contact details



Contractors to
H.M. Government Departments
Registered with ISO 9001:2015

A.T.Juniper (Liverpool) Limited Aircraft Service Equipment

Head Office:

Marshall Works, 5-17 Bleasdale Road, Allerton,
Liverpool L18 5JB, United Kingdom

Tel: +44 (0)151 733 1553

Fax: +44 (0)151 734 3166

Email: gse@juniper-liverpool.com

Web: www.juniper-liverpool.com

Also At:

Ash House, Prenton Way, North Cheshire Trading Estate,
Wirral CH43 3DU, United Kingdom