

**THE JUNIPER  
TRENT 800 LONG ENGINE  
WASH PROBES**

**JMP/TRENT/D/6935**

*(Supplied as set of two)*

**Fitment Guide**



**AIRCRAFT SERVICE EQUIPMENT**



## The TRENT 800 long engine wash probes **JMP/TRENT/D/6935**

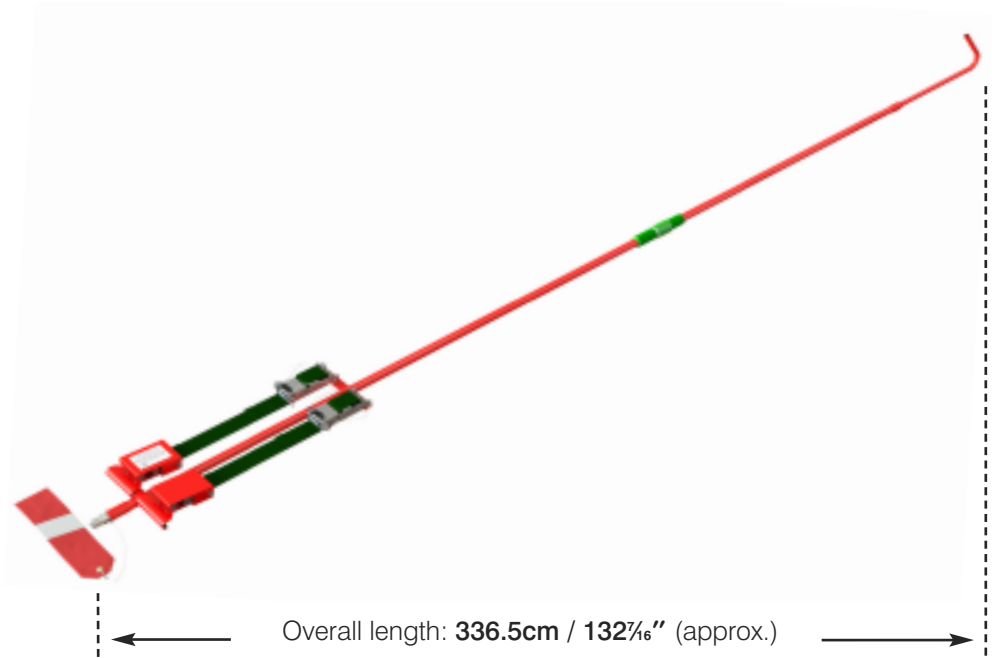

### **STEP 1:** Assembling the probes

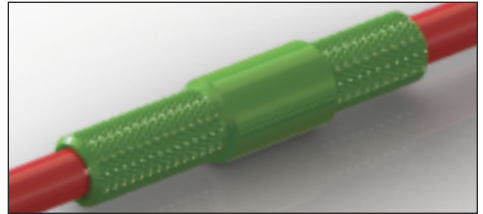
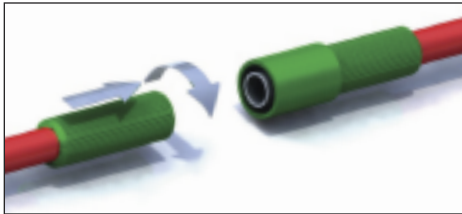

Connect probe halves by screwing together, ensuring a tight fit.

The screw connections require occasional greasing with an anti-seize compound such as Copaslip™ or equivalent grease. Take care not to get any compound in the bore of the connector.

Probes are supplied in sets of two and are identified by a red connection (port side) and green connection (starboard side).

## STEP 2: Probe fitment

**Caution: Ensure that the engine fan is held securely during the fitting of the engine 'j' hook probes.**

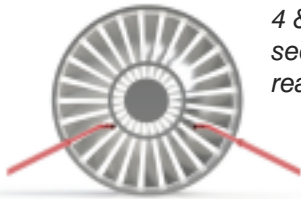

4 & 8 o'clock  
seen from  
rear of engine.

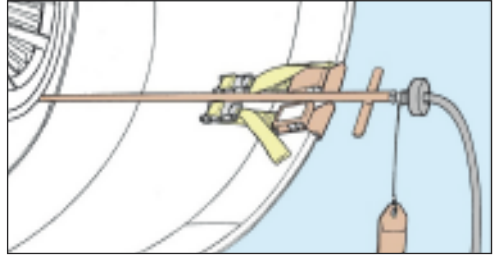

Each probe to be inserted and fitted to the engine so that the probe 'j' hook fits over the booster / fan splitter.

Guide the probes through the fan outlet guide vanes (ogv's) from the aft end, at approximately the **4 & 8 o'clock** positions, aft looking forward.

Insert each long probe carefully from the aft end & locate each tip so that it points between the booster inlet guide vanes into the booster and attach clamps.  
(See STEP 3 for clamping instructions).

Connect the twin hose assembly (provided with all compressor wash rigs) to both of the engine probes, making sure that the probes are attached securely to the engine with the hoses attached.

Connect delivery hose from the wash rig to the twin hose assembly.

**Probe installation is now complete.**

Please refer to the relevant AMM for flow rate information.

**Note:** Images used in this guide are for illustrative purposes only and may not accurately represent the equipment in question.

## STEP 3: Securing the spring clamps

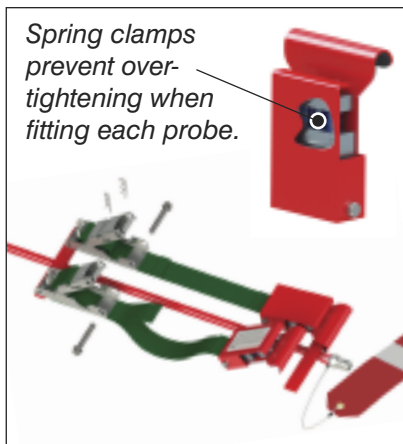

Spring clamps  
prevent over-  
tightening when  
fitting each probe.

Each probe has two spring loaded clamps which are tensioned by over centre buckle clamping devices.

To release each clamp, remove the safety clip and pin and open each clamp by pushing forward on the releasing mechanism.

This will allow the spring loaded clamp to be removed for relocation on the engine. Once relocated, pull gently on the strap and re-apply over the centre buckle.

Re-fit safety pin and clip - once the probe is inserted and located in the engine.

## Delivery hose selection



When using Trent 800 long engine wash probes, turn the three way selector to position 'A' this ensures selection of the 3/4" bore delivery hose.

**Please refer to the relevant AMM for correct flow rate information.**

## Juniper's high capacity compressor washing rigs



**The 2x25 gallon rig**  
(JMP/CFM56/D/4777/C200)  
NSN 1730-99-668-7936

**The 2x50 gallon rig**  
(JMP/LUFT/D/4972/C500)

## Contact details



### **A.T.Juniper (Liverpool) Limited** Aircraft Service Equipment

#### **Head Office:**

Marshall Works, 5-17 Bleasdale Road, Allerton,  
Liverpool L18 5JB, United Kingdom

Tel: +44 (0)151 733 1553

Fax: +44 (0)151 734 3166

Email: [gse@juniper-liverpool.com](mailto:gse@juniper-liverpool.com)

Web: [www.juniper-liverpool.com](http://www.juniper-liverpool.com)

#### **Also At:**

Ash House, Prenton Way, North Cheshire Trading Estate,  
Wirral CH43 3DU, United Kingdom



Contractors to  
H.M. Government Departments  
Registered with ISO 9001:2015